



Second Announcement
The sixth International Conference on Internal Combustion Engines (6th ICICE)

Olympic Hotel, Tehran, Iran – November 17-19, 2009



ICICE-6

Introduction

Iran Khodro Powertrain Company (IPCO) in associated with ISME (Iranian Society of Mechanical Engineers) will organize the 6th ICICE conference with collaboration of national and international universities, research centers, engine and automotive industries on **November 17-19, 2009**. It is expected that this scientific and technical event provides a forum for presenting the current and latest research and development activities in IC engines and related topics. This event will also promote the exchange of ideas and experiences amongst academia and those from industries. Furthermore the conference is intended to be an event, worthy of the attention of all engineers, postgraduate students and researchers



who are involved in the IC engines research and development. Accompanied by this event, presenting the papers, specific technical meetings, exhibition (4th International Tehran Engine Expo), workshops, and scientific and industrial festival will be organized.

organizer

Iran Khodro Powertrain Company (IPCO)

Scientific supporters

Amir Kabir University of Teccnology, Tabriz University, Tarbiat Modarres University, Tehran University, KNT University of Technology, Sharif University of Technology, Shiraz University, Iran University of Science and Technology, Mashhad Ferdowsi University, ISME, Iran Combustion Society.

Members of The Scientific Committee

No.	Name / Organization	Grade
1	Dr. Zabi Bazari	Loyds company.
2	Dr. Mehdi Behzad	Sharif University of Technology
3	Dr. Vahid Esfahanian	University of Tehran
4	Eng. Mohammad Hassan Farrokhnia	Iran Science & Technology University
5	Dr. Mohammad Farshchi	Sharif University of Technology
6	Dr. Rahmatollah Ghajar	Khajeh Nasir Technical University
7	Dr. Seyyed Ali Jazayeri	Khajeh Nasir Technical University
8	Dr. Davoud Jalai Vahid	University of Sahand-Tabriz
9	Dr. G. A. Karim	University of Calgary
10	Dr. Seyyed Hossein Mansouri	Shahid Bahonar University of Kerman
11	Dr. Mohammad Mahjoub	University of Tehran
12	Dr. Kiumars Mazaheri	Tarbiat Modarres University
13	Eng. Seyyed Mostafa mirsalim	Amirkabir University of Technology
14	Dr. Mohammad (Hameed) Metghalchi	Northeastern University
15	Dr. Ali Asghar Mozaffari	Sharif University of Technology
16	Dr. Fathollah Ommi	Tarbiat Modarres University
17	Dr. Stefan Pischinger	RWTH Aachen University , FEV Motorentechnik GmbH
18	Dr. Seyyed Mohammadreza Modarres Razavi	Ferdosi University of Mashhad
19	Dr. Morteza Sadegh Amalnick	University of Qom
20	Dr. Mohammad Hassan Saidi	Sharif University of Technology
21	Dr. Said Shabestari	Iran Science & Technology University
22	Dr. Amirreza Shahani	Khajeh Nasir University of Technology
23	Dr. Naser Soltani	University of Tehran
24	Dr. Alireza Veshagh	University of Warwick
25	Eng. Mohammad ghafouri	Engine Research Center
26	Eng. Babak sakhaei	Engine Research Center
27	Eng. Ahmad shafiei	Engine Research Center
28	Eng. Kazem khosravi	Engine Research Center
29	Eng. Majid karbasi	Engine Research Center
30	Eng. Hossein izanloo	Engine Research Center
31	Eng. Alireza firouzgan	Engine Research Center

No.	Name	Title
1	Eng. Seyyed Mostafa Mirsalim	Chairman of The Conference
2	Dr. Mohammad Hassan Saidi	Head of Scientific Committe
3	Eng. Hadi Tazari	Executive secretary
4	Eng. Ali Shalbaf	Head of Executive affairs
5	Mostafa Asadzadeh	In Charge of workshops
6	Eng.Amin Rahchamani	research and technology Dept.
8	Sina Mostowfi	In Charge of Internal Affairs
9	Farid Gharavi	IT Dept

Members of the Executive Committee of the 6th ICICE Conference

Conference Topics

The topics to be covered in the conference technical sessions will include but not exclusively:

- 1- Fuel and Combustion in IC Engines
- 2- Engine and Environment
- 3-Advanced Engines and Hybrid Powertrain Systems
- 4- Gas Engines
- 5- Powertrain Design
- 6- Powertrain Modeling and Simulation
- 7- Experimental Modeling and Analysis of Engine
- 8- Engine Management and Calibration
- 9- Materials and Manufacturing Processes of Engine Components
- 10- Noise, Vibration and Harshness (NVH)
- 11-Design of Engine Production Process and Quality Improvement.



12- Future Strategies of Internal Combustion Engines

Conference Language

The language of oral presentation and poster sessions must be The same as that of full paper.

Workshops

Technical and educational workshops will be organized on November 20, 2009. These workshops will be conducted by the national and international experts in the field of ICE in order to discuss the present and future issues of ICE, emphasizing on Engine, Fuel and Environment. . Hereby, the scientific committee invites experts and companies to present the workshops in the following topics:

- 1- Technology of reducing emmission and fuel consumption in engines and vehicles
- 2- Engine design procedures and systems
- 3- Application of specific engine simulation soft wares.
- 4- Empirical analysis of engine parts
- 5- Engine management systems and mechatronics and new methods of diagnosis
- 6- Manufacturing of engine and its parts, materials
- 7- Noise, Vibration and Harshness(NVH)
- 8- Engine and vehicle integration, design and validation
- 9- CNG engines, present and future
- 10- Hybrid vehicles
- 11- Engine benchmarking

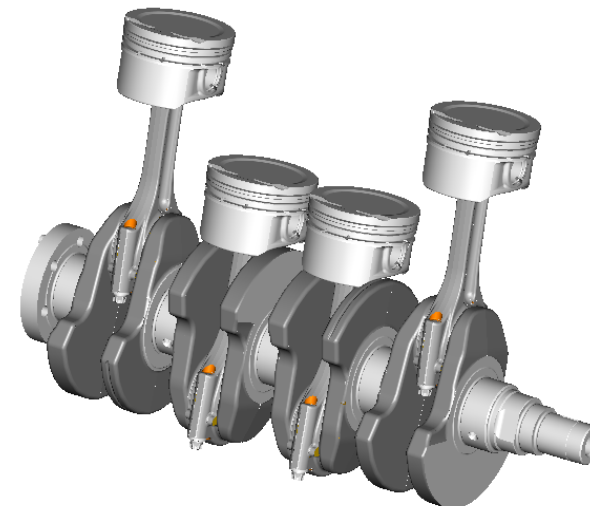

12- Diesel Engine

13- Engine Condition Monitoring

14- Reliability

15- Using Internal Combustion Engines in Decentralized power generation with combined heat and power system

Notes:

1. The workshops will be held during The Conference. The participants may attend each workshop up on registration.
2. At the end of the workshops session, a certificate will be awarded to the workshop participants.
3. The maximum capacity of every workshop will be 30 limited and priorities will be given to those which register at the proper time.

4th Tehran International Engine Expo

Contemporary to the conference, the 4th Tehran International Engine Expo will be established with special stand for:

- 1- New ideas, Innovations and Inventions
- 2- New Technologies in IC Engines
- 3- Technical Knowledge Roadmap of IC Engines
- 4- Manufacturing Technology of IC Engines

We appreciate all cooperations and encourage all experts to present their works and ideas.

Companies wishing to participate in the 4th Tehran International Expo, are kindly requested to complete the following form (all in capital letters) and

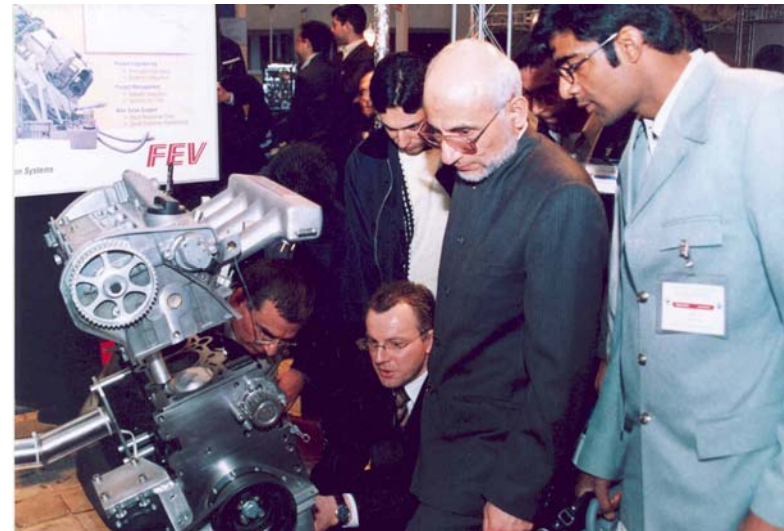

attach it to their payment details (Cheque or Bank Tranfer) and return it to the Conference secretariat by:

Phone : (+98 21) 226 32 025-9

Fax: (+98 21) 220 043 52

Email: sacco@iranengine.com

Mail : No. 19,Shokoufeh Bldg.Kadoui St. Shariati Ave.Tehran- Iran

The following will be offered to the exhibitors:

- one complimentary pass per each 12sqm.
- Fascia board with company name
- 3*100W spotlight outlet
- 2 chairs
- 1 table

(Additional equipment available upon request)

Technical Panels

Technical panels will be conducted by the eminent experts from universities, engine and automotive industries and executive organizations to challenge and discuss the following strategic subjects:

1. Engine road map in the World and Iran
2. Fuel strategy, engine and energy crisis

Scientific and Industrial Festival

In this section of the 6th ICICE, the bests in internal combustion engines will be selected and honored:

- 1- Author(s) of the best paper(s)
- 2- The best researcher(s)
- 3- Author(s) of the best book(s)
- 4- Presenters of the best ideas
- 5- Supervisors and students of the distinguished theses (BSc., MSc., and Ph.D.,)
- 6- Distinguished manufacturers



7- The bests in development, technology transfer and tailoring of engine technologies

Registration:

In order to participate in the conference, interested persons are invited to fill out the following form and send it till 6/12/2009

Registration fees

Type of registrationm	Before 21/8/2009	After 21/8/2009
Students	84,000 Rials	135,000 Rials
Other participants	1,200,000 Rials	1,150,000 Rials

Exhibition fees

Type	Fees per m ²
A	2.250.000 Rials
B	2.000.000 Rials

Please pay to the following account and send the receipt with the registration form by registered post or fax to the secretariat of the conference. Also the fees can be paid at the conference registration desk in Iran.

• **Payment methothd:**

Beneficiary: Safahan Ara Co. Account No.: 670100545 Beneficiary bank : Bank Tejarat,Isfahan branch- branch Code: 6700

S.W.I.F.T Code : DTEJIRTHISF

The registration form of the sixth international conference on internal combustion engines 17-19 Nov. 2009

First and last name:	Academic degree:	Job title:
Name of Company:	Tel:	Fax:
The postal address:		E-mail:
To present paper		
<input type="checkbox"/> To participate in the conference.	<input type="checkbox"/> Require space in exhibition.	

<input type="checkbox"/> To participate in the workshop.	<input type="checkbox"/> Workshop theme number
--	--

More informations you can search in the conference site www.IranEngine.com:

1. Information on exhibition and registration form
2. Information on workshops and registration form
3. Link to the main site of the IPCO
4. Conference registration form
5. Visa affairs
6. Hotel registration
7. Weather condition
8. The access to the venue
9. The programs of technical and site seeing tour
10. Latest information about submitted papers.

Important Information

1- Key Dates

- **Two-page summary:**

Submission deadline: February 08, 2009

Notification of acceptance: April 20, 2009

- **Full paper:**

Submission deadline: June 20, 2009

Notification of acceptance: August 05, 2009

2- The language of oral presentation must be the same as that of full paper.

3- Two-page summary and full paper must be in the standard format of conference which is available in the conference website.

4- High qualified conference papers will be peer reviewed and considered for the publication in the Journal of Engine Research.

5- Papers are eligible for publication in the conference proceedings provided that at least one of the authors of the paper register and present the paper in one of the conference sessions.

6- For more information please see the conference webpage on www.iranengine.com.

